

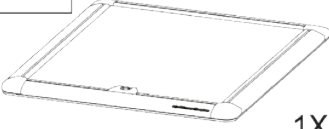

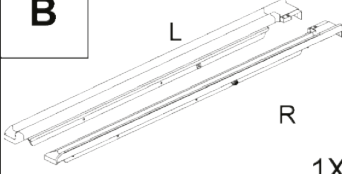

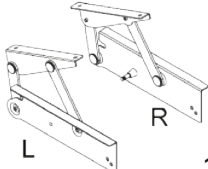

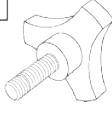



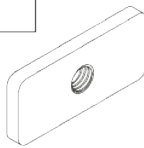
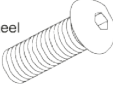



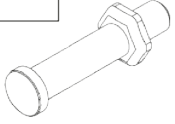

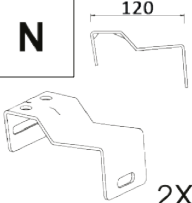
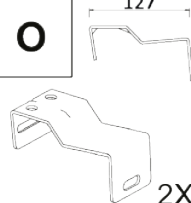
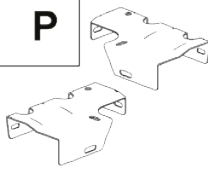

# UpStoneEvolve

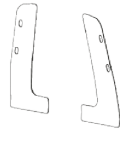
## SAILPLANE LID INSTALLATION MANUAL VW Amarok Aventura DC 2017+ EVOS200S

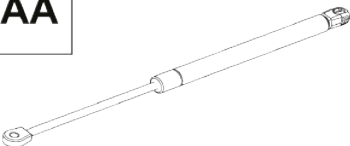
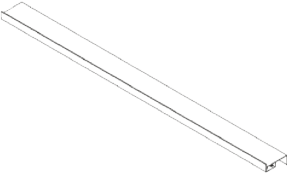
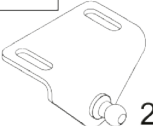
<b>A</b>  1X	<b>B</b>  L R 1X	<b>C</b>  L R 1X	<b>D</b>  2X		
<b>E</b>  2X	<b>F</b>  2X	<b>G</b> M8x20mm Stainless Steel  8X	<b>H</b> M8 x16 Stainless Steel  16X	<b>I</b>	<b>J</b> M8 Nylock Stainless Steel  8X
<b>K</b> M8 Stainless Steel Spring Washer  2X	<b>L</b>  2X	<b>M</b> 112  2X	<b>N</b> 120  2X	<b>O</b> 127  2X	<b>P</b>  L+R 1X
<b>Q</b> M6x13mm Zinc  8X	<b>R</b> M6x10mm  8X	<b>S</b> M6x18  8X	<b>T</b>  L+R 1X	<b>U</b> M8 Nylock Zinc  4X	<b>V</b> M8 x16 Zinc Washer  8X
<b>W</b>	<b>X</b>	<b>Y</b>	<b>Z</b>	<b>AA</b>  2X	
<b>AB</b>  1X	<b>AC</b>  2X	<b>AD</b> M8 SS SPACER  2X	<b>AE</b> M5 Nylock Zinc  4X	<b>AF</b> M5x18 Zinc  4X	<b>AG</b>
<b>AH</b>	<b>AI</b> 25x 20mm 	<b>AJ</b>  2X	<p><b>Note:</b> If at any stage of installation you find your Aluminium Tonneau Cover to be an unacceptable fit please contact the manufacturer before continuing.</p> <p><b>Tools Required:</b></p>  <p>BLACK SILICONE 3 + 5mm Hex Key 14mm Wrench</p>		
<b>Fitting Kit Number</b> EVOS200	<b>Product</b> UpStone Sailplane Lid	<b>Revision</b> 1	<b>Date</b> 23-04-2019	<b>Page</b> 1 of 8	

1

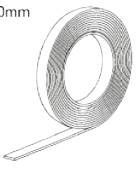
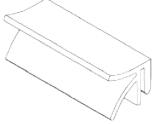
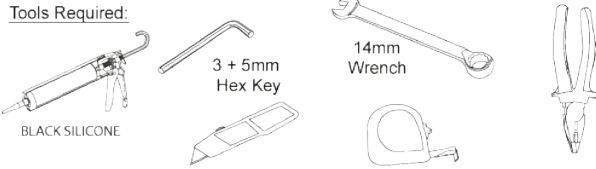
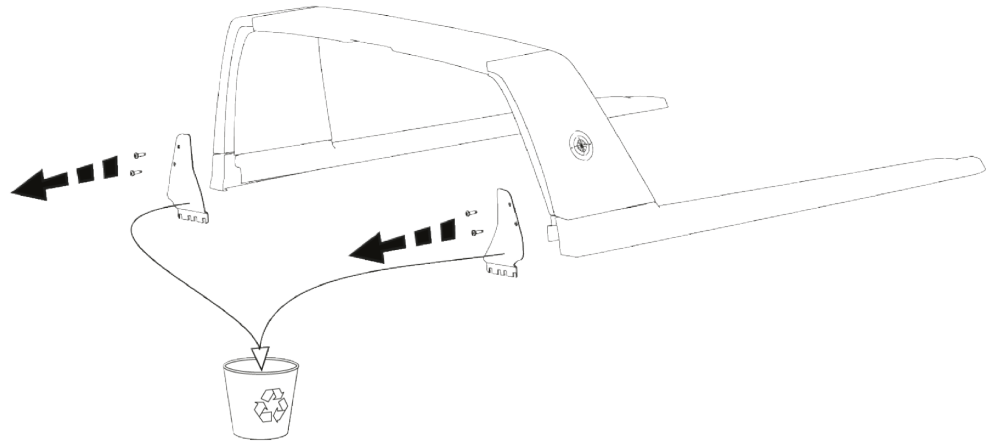

2

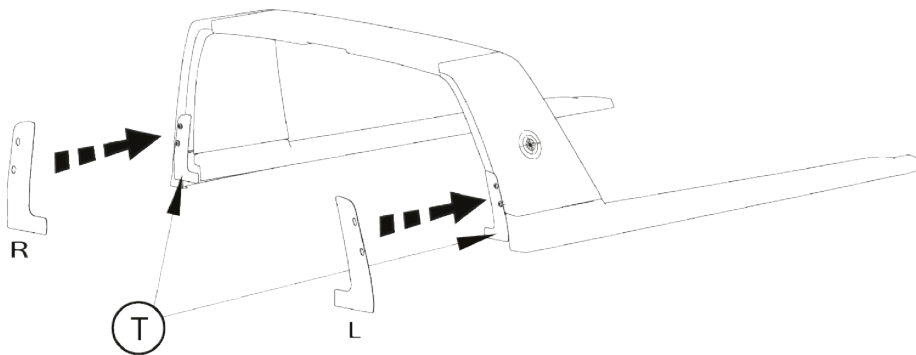

3

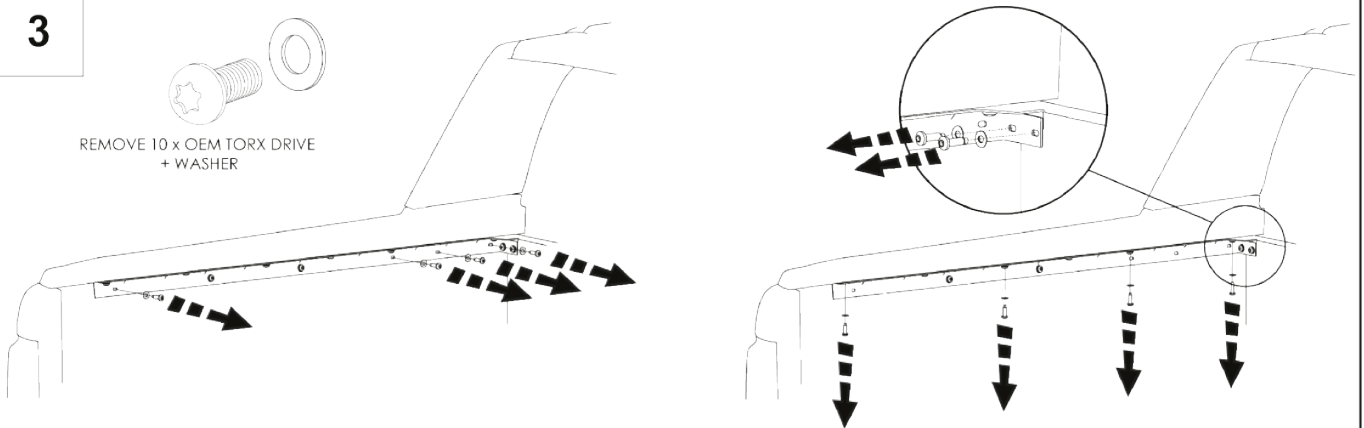

4

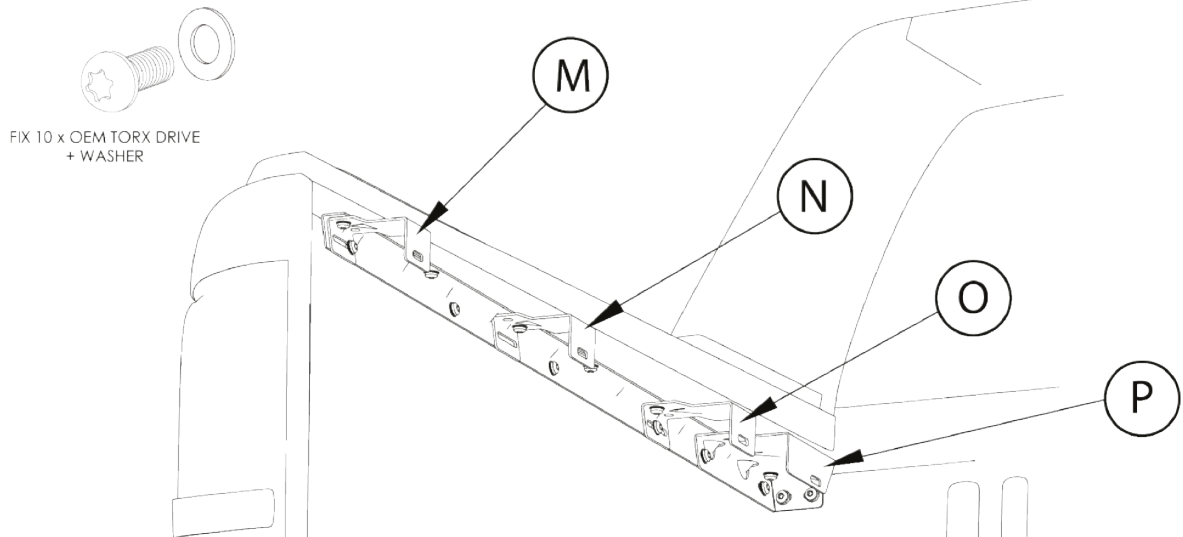

Fitting Kit Number	Product	Revision	Date	Page
EVOS200	UpStone Sailplane Lid	1	23-04-2019	2 of 8

5

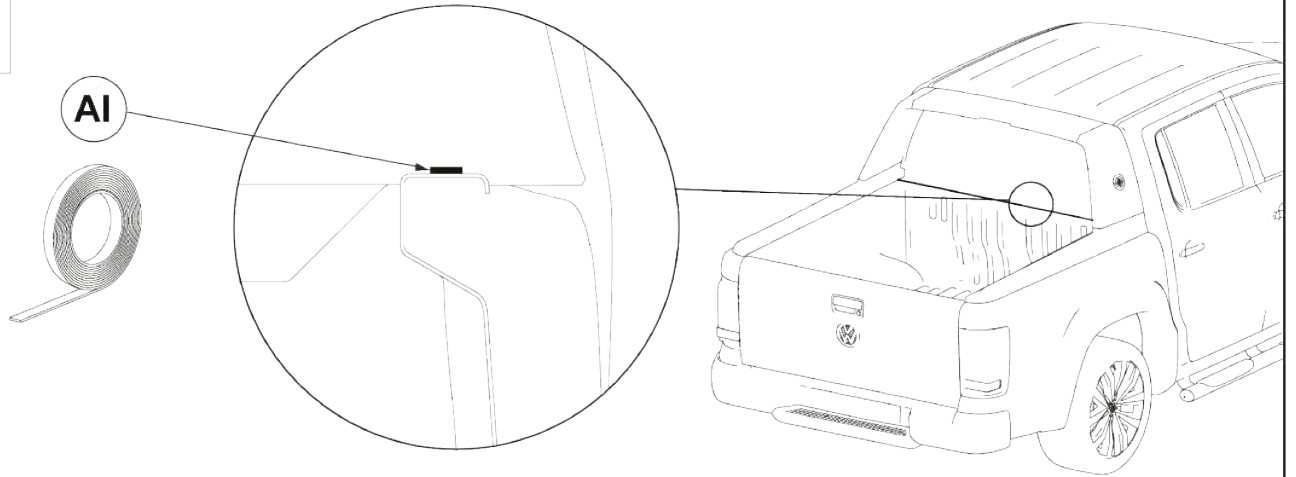

6

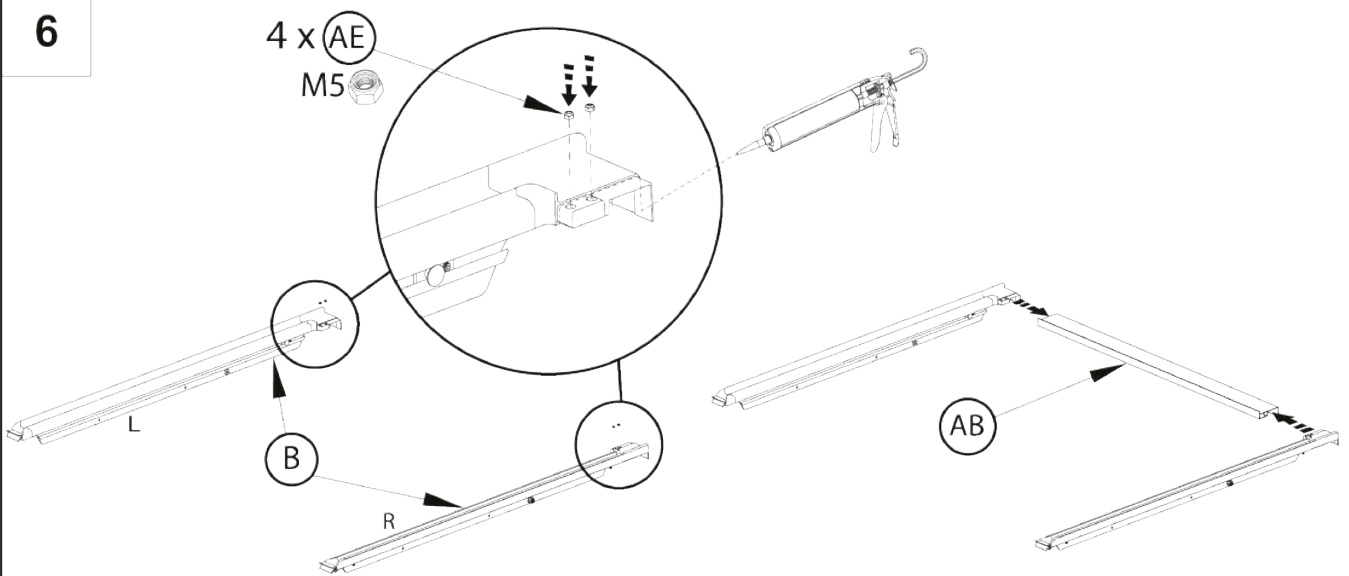

7

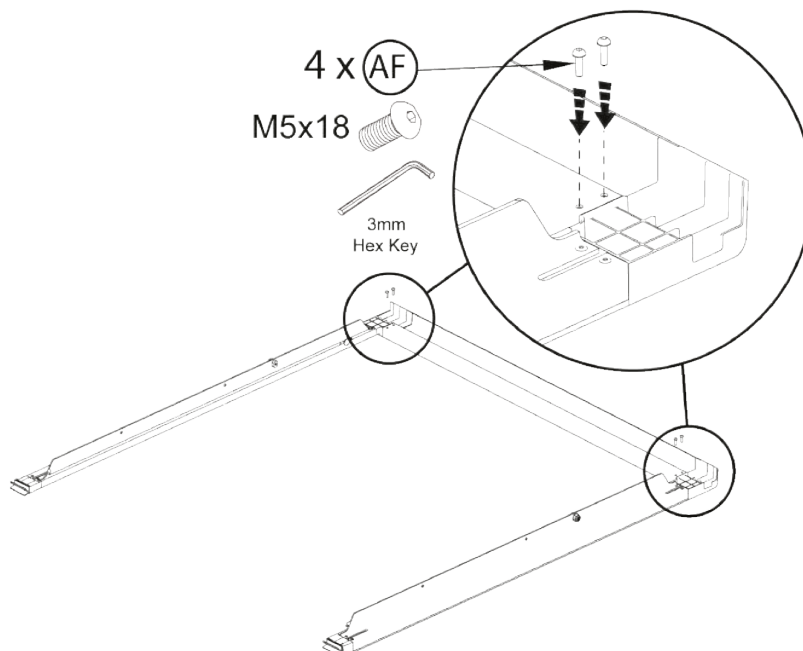

Fitting Kit Number	Product	Revision	Date	Page
EVOS200	UpStone Sailplane Lid	1	23-04-2019	3 of 8

8

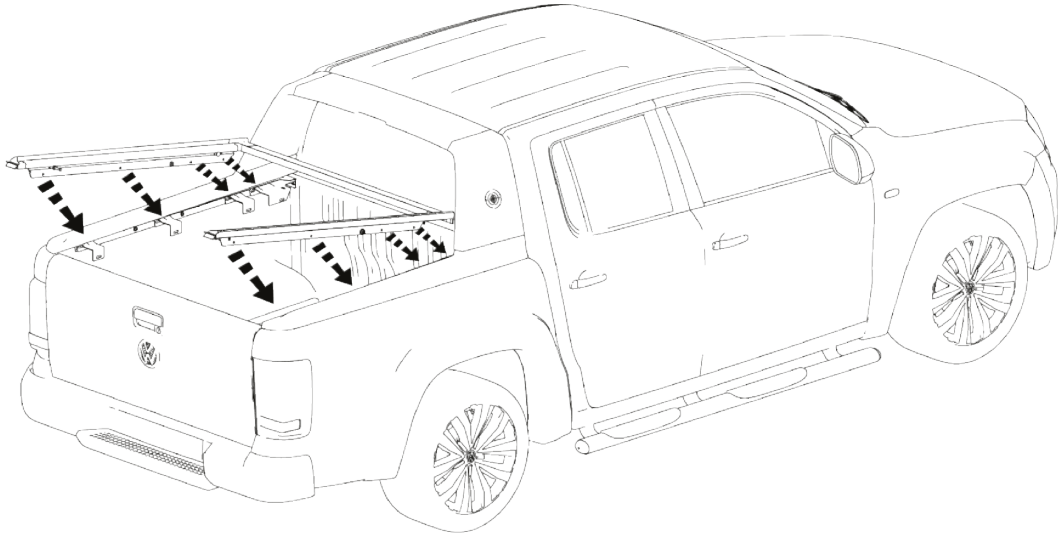

9

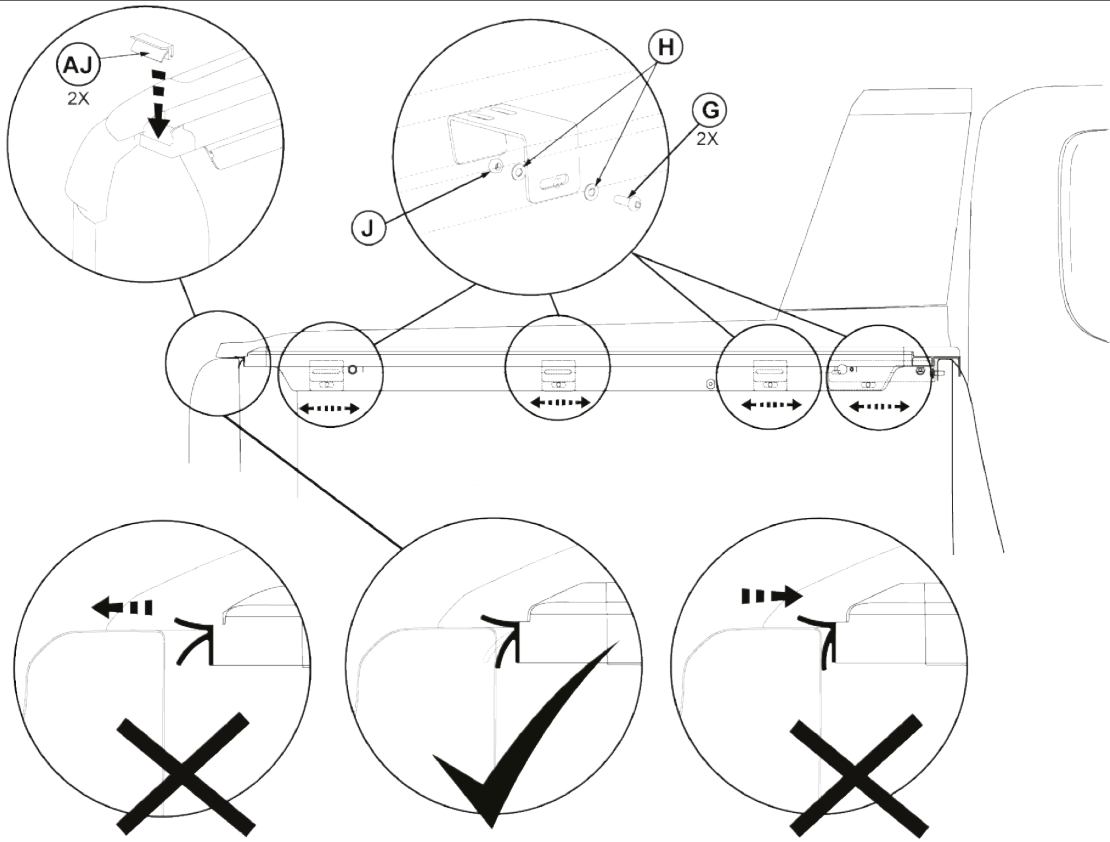

10

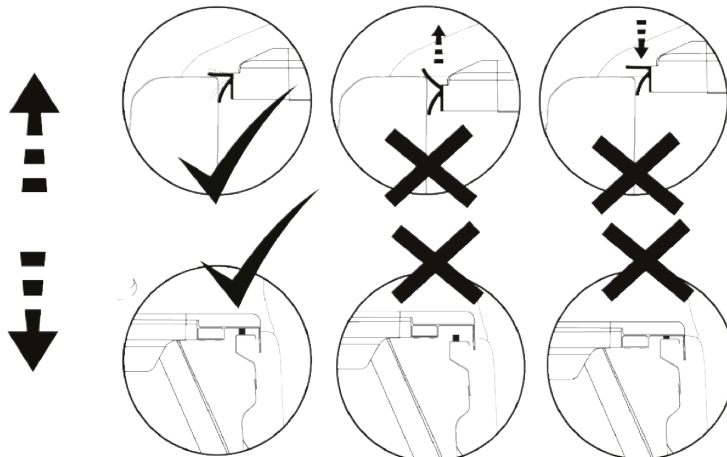

Fitting Kit Number	Product	Revision	Date	Page
EVOS200	UpStone Sailplane Lid	1	23-04-2019	4 of 8

11

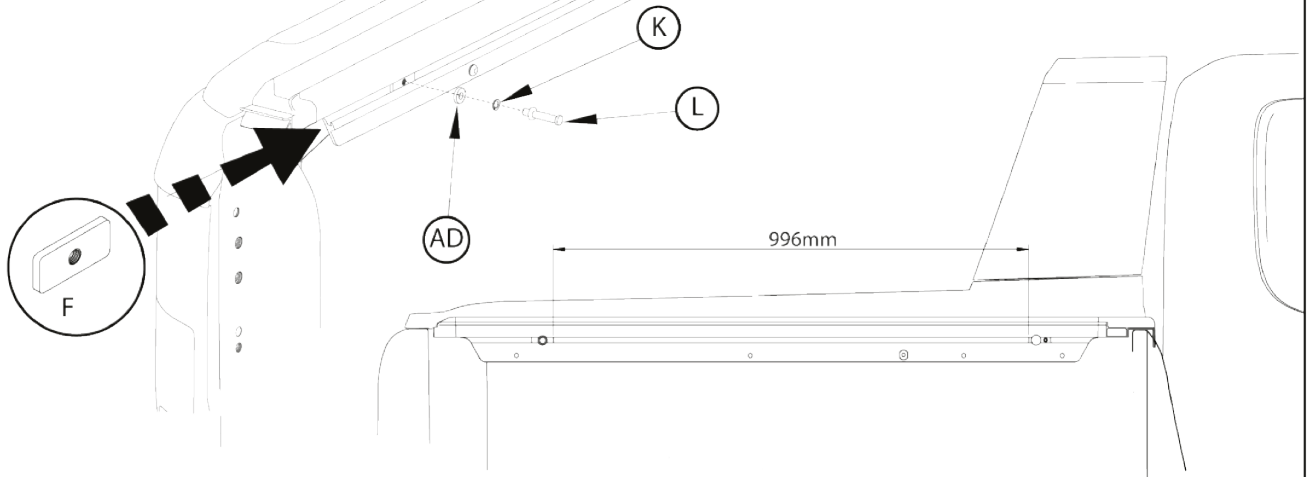

12

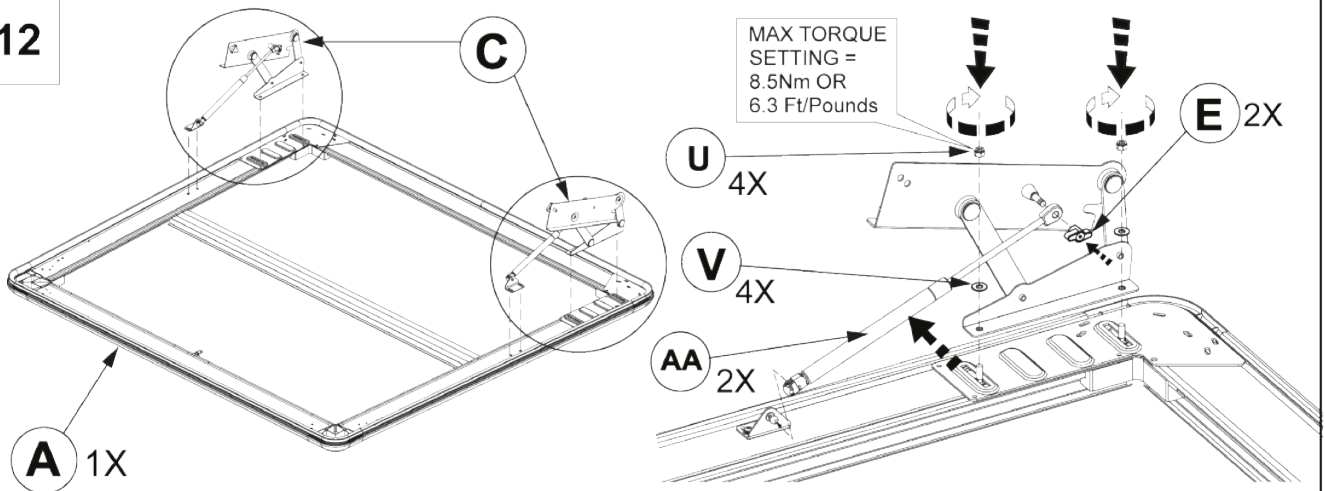

Vehicle Model	Π	Θ
	mm	mm
VW Amarok V6 Aventura DC 2017+	24.5	24.5

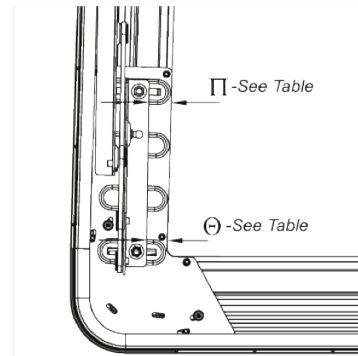

13

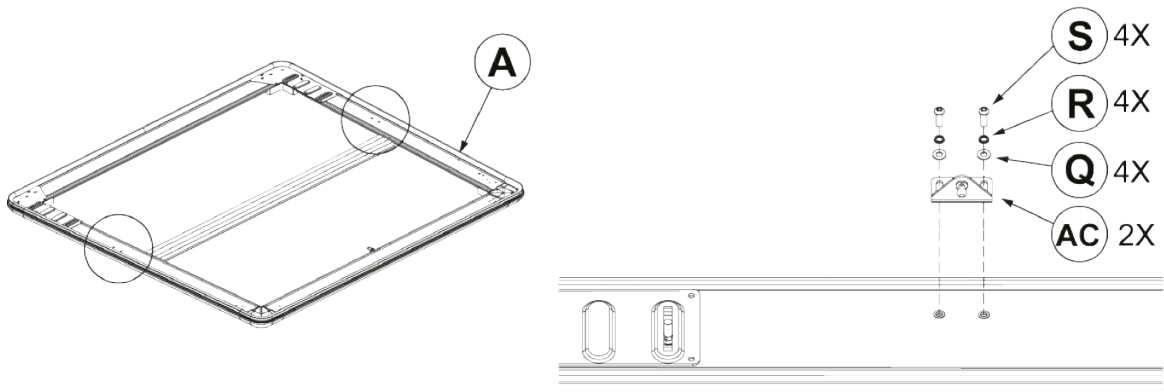

16

MAX TORQUE SETTING = 8.5Nm OR 6.3 Ft/Pounds

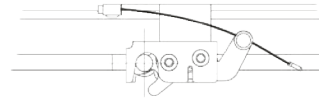
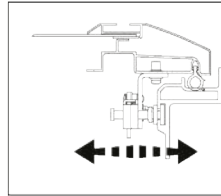
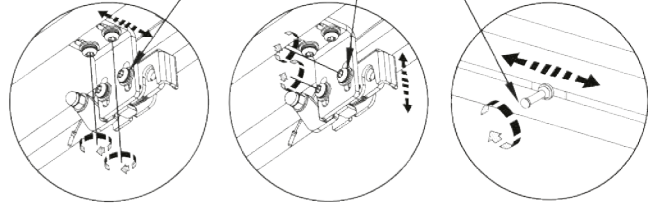
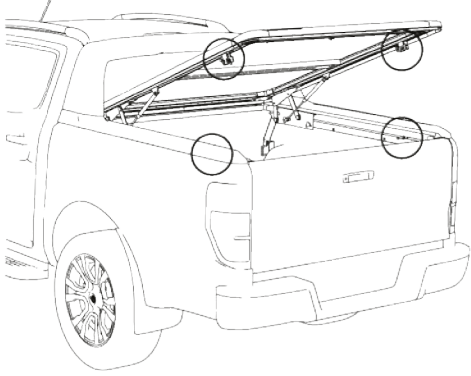

Adjust latch bracket, latch height and pin location to align pin with centre of latch. Adjust cable tension to achieve correct latching. **IMPORTANT!** : Ensure seal contacts vehicle in all areas

17

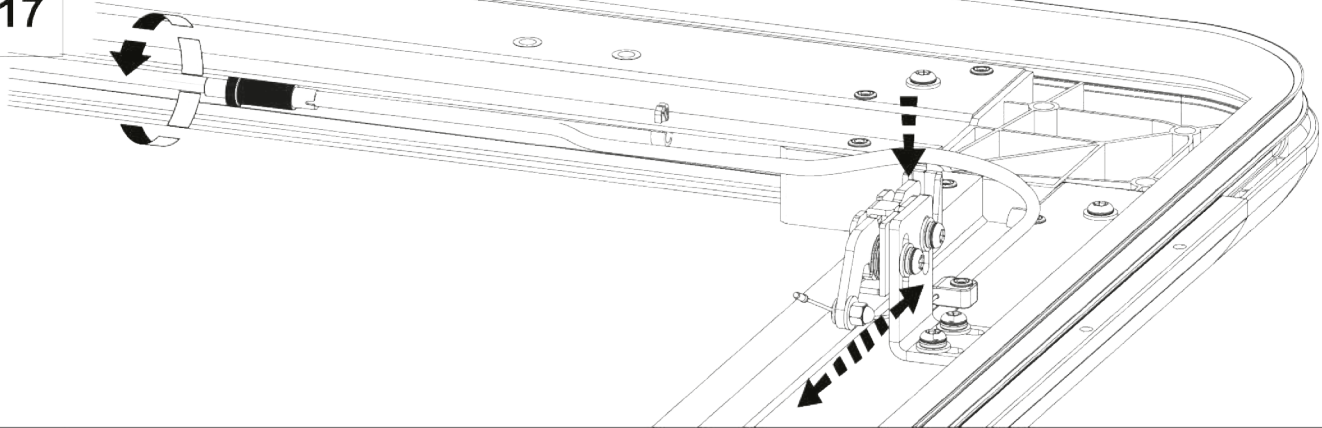

18



Insure hinge is not twisted. Adjust connection to lid if nessessary.

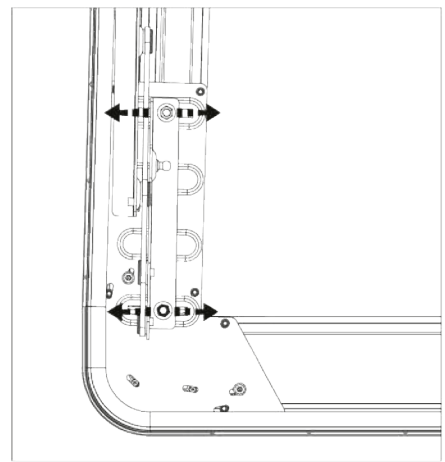
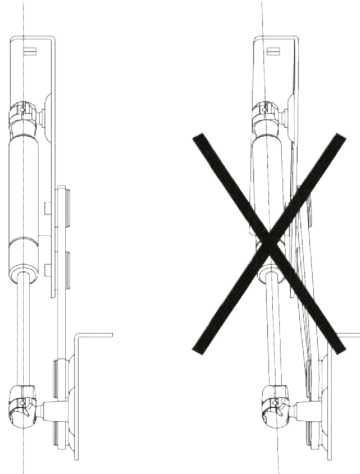

20

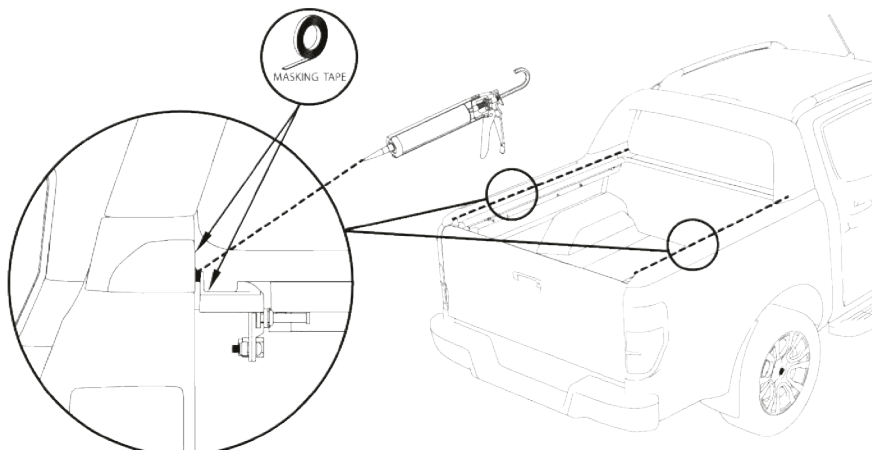

Fitting Kit Number	Product	Revision	Date	Page
EVOS200	UpStone Sailplane Lid	1	23-04-2019	7 of 8